

Vector Frame Kit 03

VF-K-03

Stand apart from the competition with a clean, sophisticated 10' x 10' or 10' x 20' Vector Frame™ exhibit kit. These graphic mural kits feature square-corner 50mm extrusion frames and push-fit fabric graphics that cover the entire frame. Vector Frame Essential kits are easy to assemble and disassemble.



features and benefits:

- 50mm silver extrusion frame
- Single-sided SEG dye-sublimated push-fit fabric graphics
- Easy step-by-step instructions
- Kit includes frame, four fabric graphics, three 120 watt lights, one wheeled molded case
- Lifetime hardware warranty against manufacturer defects

dimensions:

Hardware	Graphic
<p>Assembled unit: 112.7" w x 94.5" h x 28" d 2863mm(w) x 2400mm(h) x 711mm(d)</p>	<p>Refer to related graphic template for more information.</p> <p>Visit: www.exhibitors-handbook.com/graphic-templates</p>
Shipping	additional information:
<p>Packing case(s): 1 OCH2</p> <p>Shipping dimensions: 52" w x 29" h x 15" d 1321mm(w) x 737mm(h) x 381mm(d)</p> <p>Approximate total shipping weight (includes cases & graphics): 102 lbs / 46 kgs</p>	<p>Graphic material: Dye-sublimated fabric</p> <p>Lights included: Lumina 200 120 watt floodlight, curved arm, black finish, 19.5" from end to end</p>

We are continually improving and modifying our product range and reserve the right to vary the specifications without prior notice. All dimensions and weights quoted are approximate and we accept no responsibility for variance. E&OE. See Graphic Templates for graphic bleed specifications.

Included In Your Kit

Extrusions, Tools, & Components



5MM ALLEN-T x1

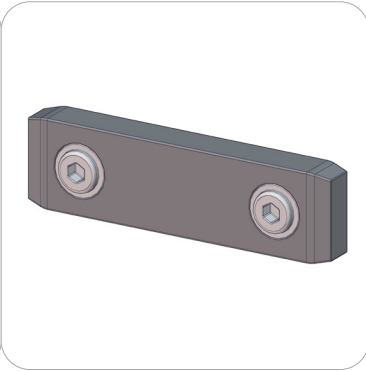

IB2 x8

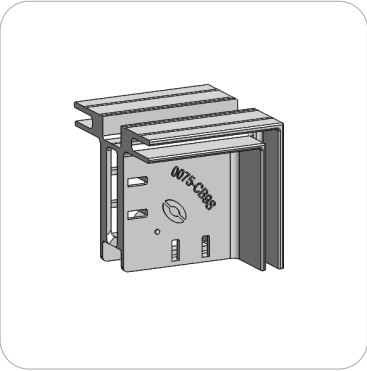

CB9-S x4

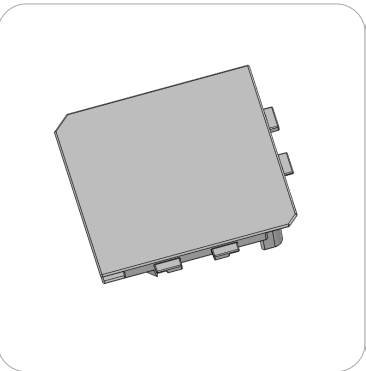

PMFC2-90-CAP x6



PHFC2-1155-L-L1 x4

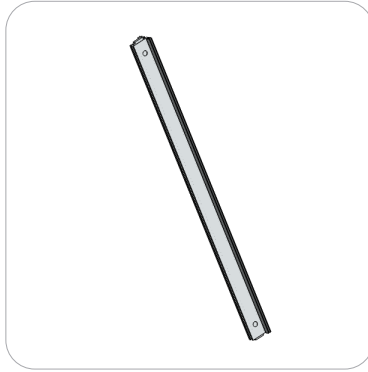

PHFC2-900-L-L x2

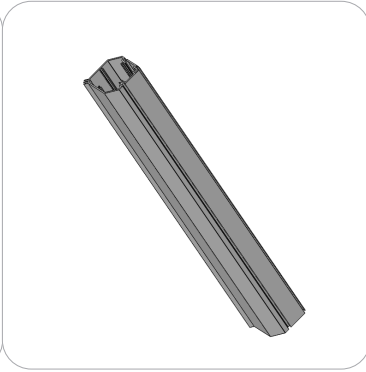

PMFC2-90-1193-L1-L1 x6



PHFC2-600-L-L x4



LUM-200-ORL x3

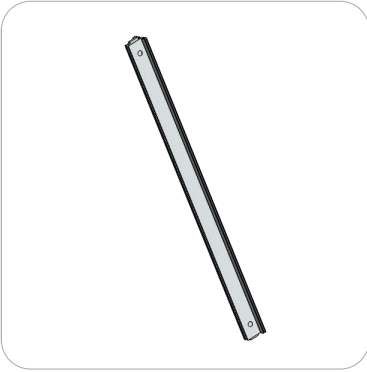

PHFC2-900-L-L1 x4

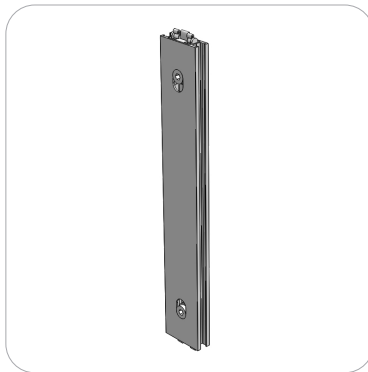

PH-1155-L1-S

Included In Your Kit

Graphics



VF-03-A-G x1



VF-03-B-G x1

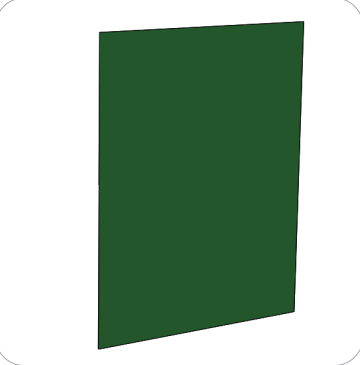

VF-03-C-G x1



VF-03-D-G x1

Exploded View

VF-K-03

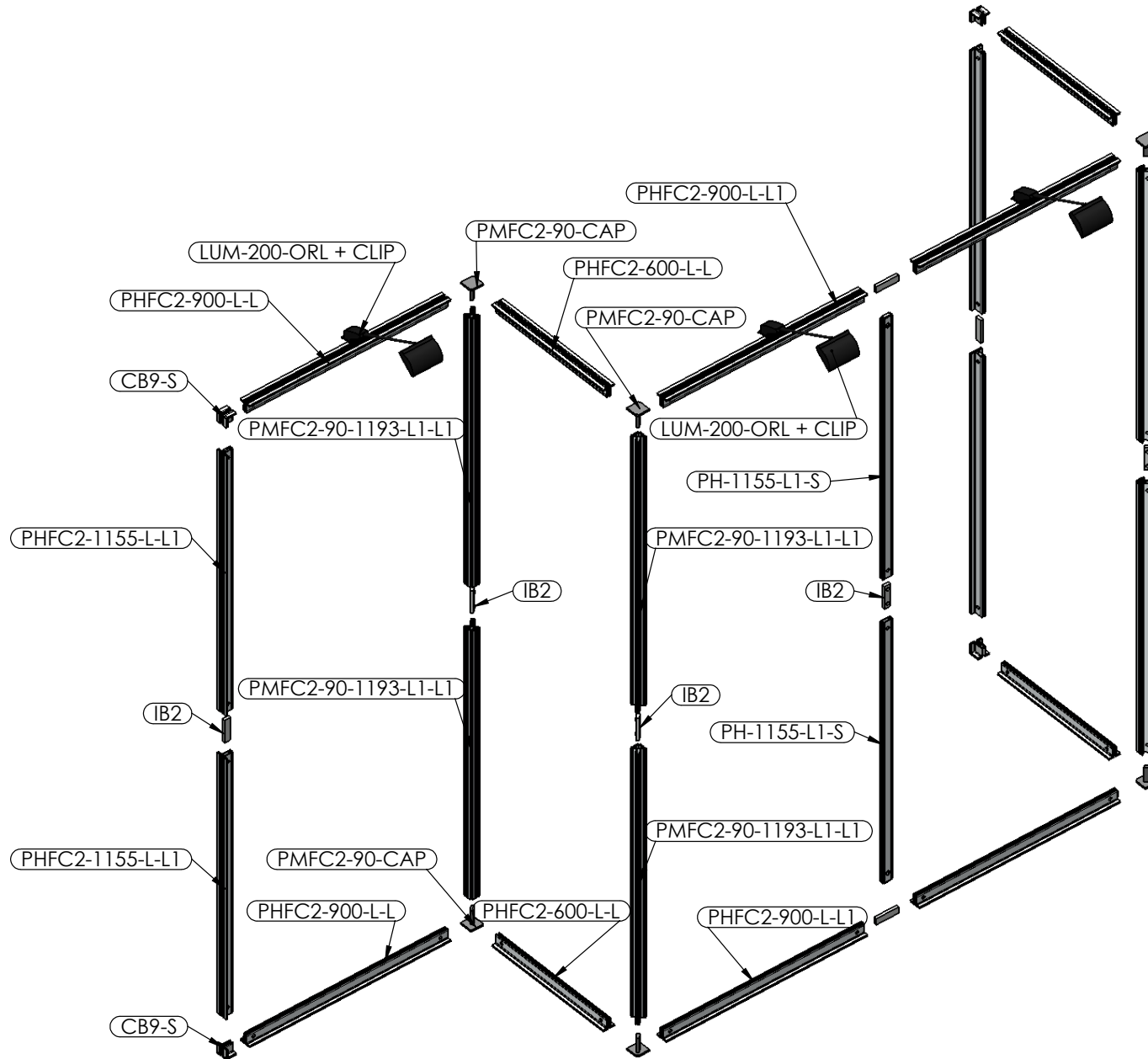

Connection Methods

Extrusion based structures use a number of different yet simple connection methods. Your kit will include one or more of the connection methods shown below. Steps within the Kit Assembly will reference a specific method for each connection point.

Connection Method 1: Cam Lock / Slide Lock

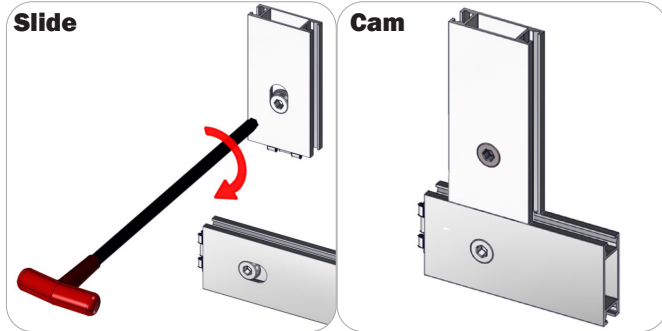

A cam lock equipped extrusion can lock to any cam lock channel. With the cam lock unlocked, set the teeth of the cam lock into the desired position on the cam lock channel. Using your allen key tool, carefully turn the lock clockwise to lock in place. Be sure to lock securely, but do not overtighten.

A slide lock equipped extrusion can also lock into any cam lock channel. When the slide lock is unlocked, pull back on the hex bolt head to retract the slide lock into the body of the extrusion. Slide locking procedure is the same as a cam lock.

Connection Method 2: IB2 / Corner Brackets

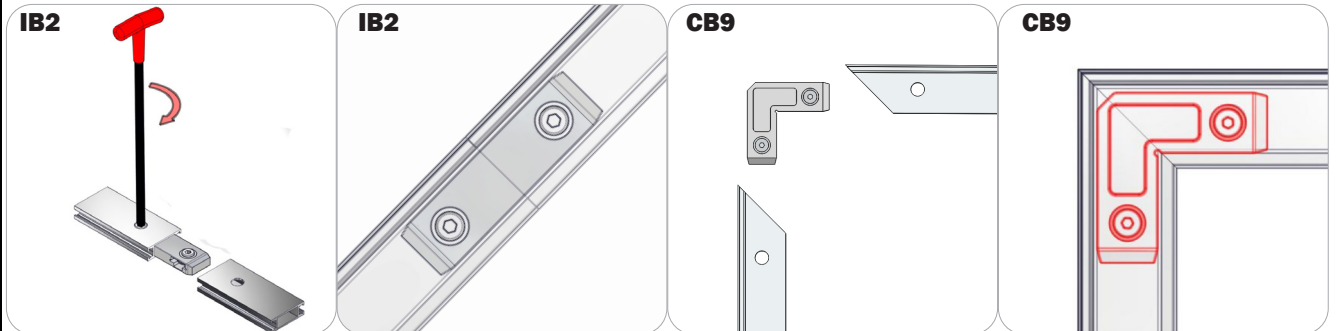

Press the hex bolt head in with your thumb and slide the extrusion and connector together so that the hex bolt head sits into the lock hole. Repeat with the second extrusion to the free end of the connector. Lock the extrusions together by turning carefully with the allen key tool. Be sure to lock securely, but do not overtighten.

Connection Method 3: SW-FOOT

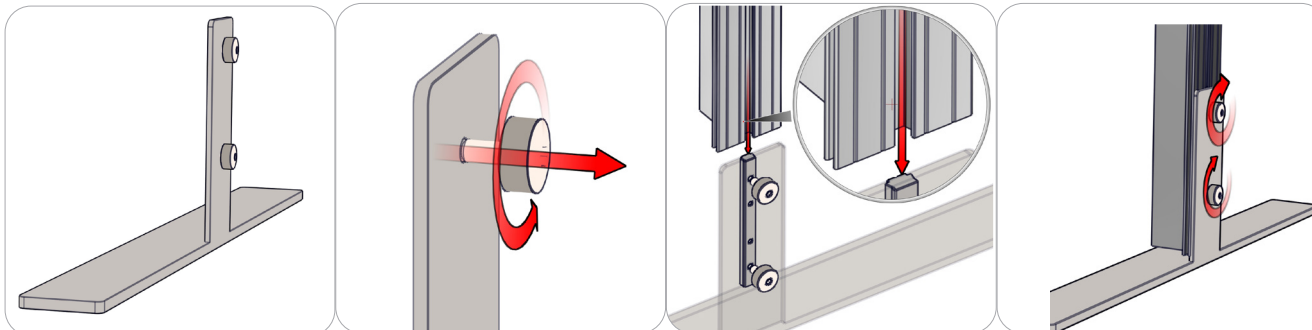

An SW-FOOT assembly consists of two thumb screws, an LN100, and SW-FOOT baseplate. Start by loosening the thumb screws (it is best not to completely remove the screws). Slide the extrusion onto the LN100 by utilizing its back cam channel. When the extrusion rests on baseplate or ground (depending on application), tighten the thumb screws to lock in place. Do not overtighten.

Kit Assembly

Step by Step

Step 1.

Assemble your frame using the Exploded View page for reference.

Please reference Connection Methods 1 & 2 for more details.

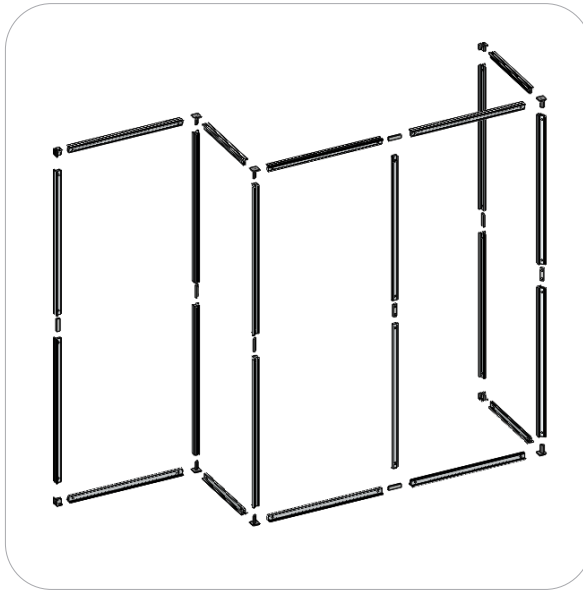
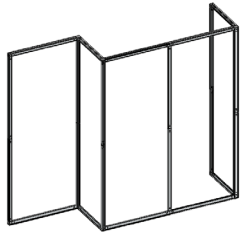

Step 2.

Install your graphics. Push the silicone beading on the edges of your graphic into the channels of the PHFC2, as shown in the figure below.

FCE-2 TO PHFC2

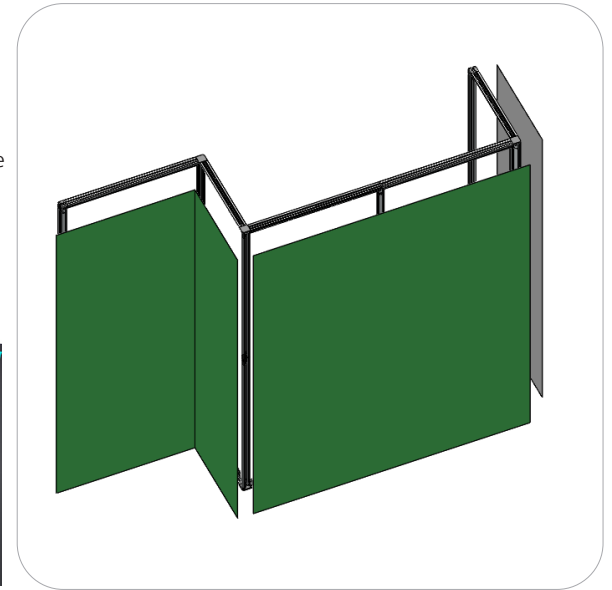
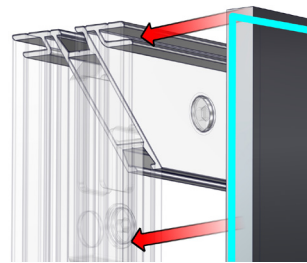

Step 3.

Apply the spotlights to your kit. Using the appropriate included clip, slide the light into the top channels.

Setup Complete

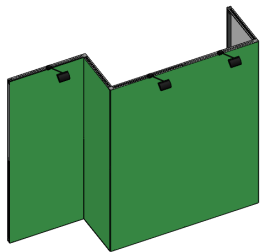

L10 LIGHT

1-

2-

PHFC2

1- Slide light clip onto the LIGHT.
2- Then slide the LIGHT into the channel at an angle and then gently lower down.